

# torpeDNA



The **torpeDNA** is a groundbreaking water sampling device. Its innovative features include affordability, compact size, and enhanced usability, facilitated by a streamlined torpedo design that enables operation at higher speeds. This device surpasses alternative solutions, providing a more efficient means of obtaining biological samples from water. Its utilization promises not only enhanced monitoring of aquatic environments but also empowers science initiatives by providing a simple and robust method to collect data. Ultimately, **torpeDNA** contributes to the creation of high-resolution biological data models.



## COST-EFFECTIVE SOLUTION

Affordable compared to existing eDNA sampling devices in the market.



## SIMPLE TO USE

Traditional plankton nets suffer from size, complexity, weight, and towing challenges.



## HIGH-SPEED TOWING

The **torpeDNA** design enables the collection of water samples even at speeds exceeding 12 knots.



## NO TRAINING COST ASSOCIATED

Following a simple protocol, anyone can use **torpeDNA**.



## EMPOWERS CITIZEN SCIENCE

Providing a simple and robust method to collect data contributes to the creation of high-resolution biological data models.

## PRODUCT APPLICATION

Traditional plankton nets suffer from size, cost, complexity, weight, and towing challenges, often exceeding \$2,500 in price, being cumbersome, and being restricted to a towing speed of only 2 knots. Additionally, the robust processing of the samples after collection is challenging in an ocean environment. In contrast, **torpeDNA** emerges as a superior alternative — it is not only more affordable and compact but also boasts enhanced durability, ease of use at speeds exceeding 12 knots, and simple sample processing. This portable eDNA sampler stands out as a more convenient, practical, and cost-effective solution compared to existing options in the market.



## WORLD-CLASS SCIENCE FOR A BETTER FUTURE

At Cawthron, we deliver world-class science to drive a better future. Our in-house development of **torpeDNA** showcases our commitment to quality and innovation. This cutting-edge device surpasses alternative solutions enhancing the monitoring of aquatic environments and empowering citizen science initiatives by offering a simple and robust method for data collection. Ultimately, **torpeDNA** contributes to the creation of high-resolution biological data models, underscoring our dedication to advancing scientific knowledge and environmental stewardship.

## PRODUCT SPECIFICATIONS

### Dimensions:

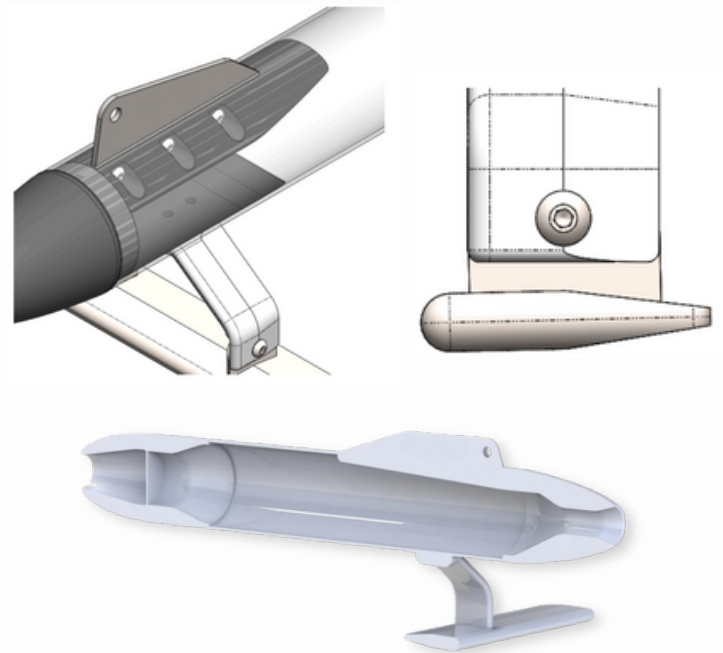
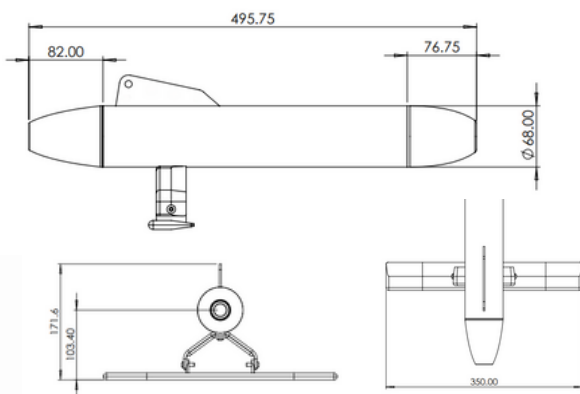

**Weight:** 1200 gr.

**Recommended filters:** Sigma Aldrich 20µm Nylon Net 47 mm

 98 Halifax Street, Nelson, New Zealand

 +64 3 548 2319

 [www.cawthron.org.nz](http://www.cawthron.org.nz)

 [info@cawthron.org.nz](mailto:info@cawthron.org.nz)